

METRIC

MIL-PRF-85045/25B

17 June 2014

SUPERSEDING

MIL-PRF-85045/25A

19 January 2010

PERFORMANCE SPECIFICATION SHEET

CABLE, FIBER OPTIC, SEVEN TUBE, BLOWN OPTICAL FIBER, STANDARD AND ENHANCED PERFORMANCE, CABLE CONFIGURATION TYPE 5 (TUBE), APPLICATION B (SHIPBOARD), CABLE CLASS SM AND MM

This specification is approved for use by all Departments and Agencies of the Department of Defense.

The requirements for acquiring the product described herein shall consist of this specification sheet and MIL-PRF-85045.

CLASSIFICATION:

Fiber optic cable configuration type: 5 (tube)

Fiber optic cable class: MM (graded-index, glass core and glass cladding, multimode)

SM (dispersion-unshifted, glass core and glass cladding, single-mode)

DESIGN AND CONSTRUCTION:

Blown optical fiber tube:

Dimensions and configuration: See [figure 1](#).

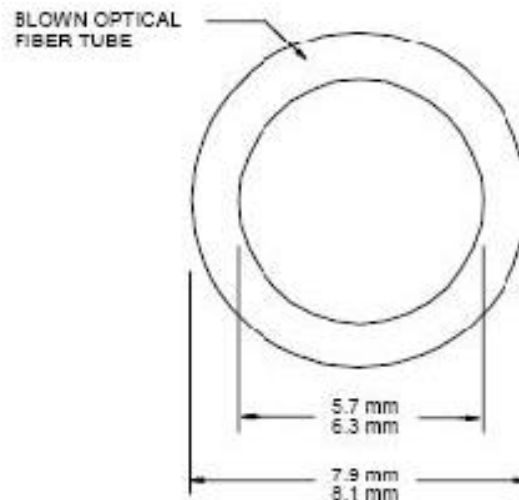

FIGURE 1. Blown optical fiber tube.

Short-term minimum bend diameter: 127 mm

Long-term minimum bend diameter: 127 mm

Tensile loading: ≥ 89 N

Tube material: The tube shall be composed of a low halogen, low smoke, low toxicity polymer material.

Tube marking: Each tube shall be uniquely marked with a number between 1 and 7. The form of the marking shall be the printed spelling of the number, followed by a dash, followed by the printed Arabic numeral. The marking shall be applied and repeated every 0.10 m (4 in) along the tube. Tube number 1 shall be located in the center of the cable.

Finished cable:

Dimensions and configuration: See [figure 2](#). Six tubes shall be helically laid over a central tube. The minimum outer jacket thickness shall be not less than 1.65 mm.

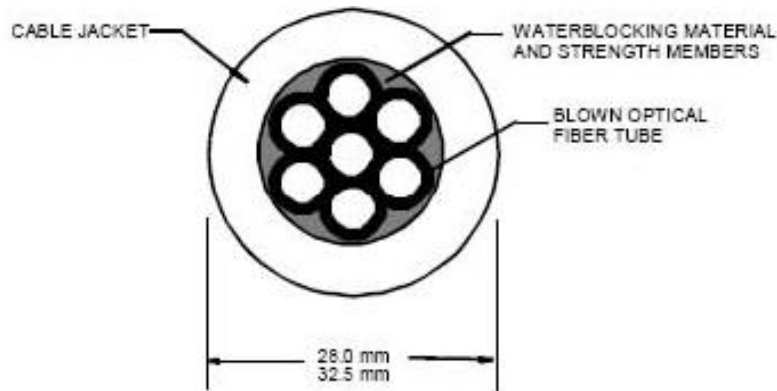

FIGURE 2. Seven-tube cable.

Concentricity: ≥ 0.65

Jacket material: The overall jacket shall be composed of a low halogen, low smoke, and low toxicity polymer material.

Cable jacket color: Shall be black or blue.

Mass per unit length: ≤ 775 kg/km

Short-term minimum bend diameter: 0.45 m. (The short-term minimum bend diameter is to be used in all environmental and mechanical tests that specify a cable minimum bend diameter.)

Long-term minimum bend diameter: 0.45 m

PERFORMANCE REQUIREMENTS:

Specimen lengths: 3 units, 0.305 km each.

Optical properties:

Attenuation rate: Not applicable.

Change in optical transmittance: Not applicable.

Crosstalk: Not applicable.

Mechanical properties:

Tensile loading and elongation: Applicable, tensile loading ≥ 3300 N. Change in optical transmittance is not applicable. A ball bearing with a minimum outer diameter of 4 mm shall pass through each tube after the test.

Operating tensile loading: Applicable, except change in optical transmittance is not applicable. A ball bearing with a minimum outer diameter of 4 mm shall pass through each tube during and after the test.

Dynamic bend: Not applicable.

Low temperature flexibility: The following procedure shall be used. A 1.5-m test specimen shall be placed in a straight configuration and conditioned at the exposure temperature for 4 hours. For standard performance cable, the exposure temperature shall be the minimum operating temperature. For enhanced performance cable, the exposure temperature shall be $-40\text{ }^{\circ}\text{C}$. The test specimen shall be removed from the conditioning chamber and formed into a single loop around a mandrel with a diameter equal to the cable short-term minimum bend diameter. The time between the removal of the cable from the chamber to the completion of the loop shall be a maximum of 50 seconds. The specimen shall be secured to maintain its bent shape and allowed to return to room temperature. A ball bearing with a minimum outer diameter of 4 mm shall pass through each tube after the test.

Cyclic flexing: 100 cycles at $+25\pm 2\text{ }^{\circ}\text{C}$ and 20 cycles at $-28\pm 2\text{ }^{\circ}\text{C}$. Change in optical transmittance is not applicable. A ball bearing with a minimum outer diameter of 4 mm shall pass through each tube after every 25 cycles for the 100-cycle exposure and after the 20-cycle exposure. The cycling may be halted to perform the ball bearing test.

Crush: Applicable, except that the load shall be 2650 N and the change in optical transmittance and crosstalk are not applicable. A ball bearing with a minimum outer diameter of 4 mm shall pass through each tube after the load is removed.

Cable twist-bending: Not applicable.

Radial compression: Applicable, except the change in optical transmittance is not applicable. A ball bearing with a minimum outer diameter of 4 mm shall pass through each tube during and after the test.

Impact: Applicable, except that the drop hammer mass shall be 6 kg. Fifty cycles shall be conducted at $+25\pm 2\text{ }^{\circ}\text{C}$ and 20 cycles shall be conducted at $-40\pm 2\text{ }^{\circ}\text{C}$. The change in optical transmittance is not applicable. A ball bearing with a minimum outer diameter of 4 mm shall pass through each tube after the test.

Corner bend: Applicable, except the change in optical transmittance is not applicable. A ball bearing with a minimum outer diameter of 3 mm shall pass through each tube during the test. A ball bearing with a minimum outer diameter of 4 mm shall pass through each tube after the test.

Cable jacket tear strength: Applicable, except the cable jacket tear strength shall be not less than 35 N/cm of jacket thickness for standard performance cable.

Tube tensile strength and elongation: Tube specimens shall be tested in accordance with FED-STD-228, Method 3021 and 3031, with 2.5-cm (0.98-in) benchmarks, 6.35-cm (2.5-in) jaw separation, and a rate of travel of 25 cm/min (9.8 in/min). The tensile strength of the tube shall be not less than 900 N/cm^2 . The percent elongation-at-break shall be not less than 125 percent. Capstan grips may be used.

Hosing: Low pressure applicable, except the cable leakage shall be not greater than 175 mL. Tube ends shall be capped with end caps during this test.

Hydrostatic: Not applicable.

Cable scraping resistance: 750 cycles

Cable-to-cable abrasion: 500 cycles

Cable shrinkage: Applicable, except that the total shrinkage shall be not greater than 35 mm.

Pressure withstand: One end of three tubes shall be capped and a static pressure of 1.4 MPa (200 psi) applied internal to the tube for 10 minutes. After the test, tubes shall show no evidence of splitting, cracking, or rupture. Perform as part of Group I on tubes in each of the 0.3-km samples.

Environmental properties:

Temperature range:

Operating:	$-28\text{ to }+65\text{ }^{\circ}\text{C}$
Nonoperating:	$-40\text{ to }+70\text{ }^{\circ}\text{C}$
Storage:	$-40\text{ to }+70\text{ }^{\circ}\text{C}$

Temperature cycling: Change in optical transmittance is not applicable. A ball bearing with a minimum outer diameter of 4 mm shall pass through each tube at the high temperature plateau, the low temperature plateau, and after the test.

Thermal shock: Not applicable.

Temperature humidity cycling: Change in optical transmittance is not applicable. A ball bearing with a minimum outer diameter of 4 mm shall pass through each tube at the high temperature plateau, the low temperature plateau, and after the test.

Storage temperature: Applicable, except the change in optical transmittance is not applicable. A ball bearing with a minimum outer diameter of 4 mm shall pass through each tube after the test.

Temperature life (life aging): Applicable, except the change in optical transmittance is not applicable and a minimum test sample length of 150 m may be used. For standard performance product, the test shall be conducted as specified in the general specification. For enhanced performance product, the test shall be conducted as specified in the general specification except that the jacket material shall be tested at +175 °C for 4 hours. A minimum of 2 m of the sample shall be maintained at the minimum bend diameter throughout the test. A ball bearing with a minimum outer diameter of 4 mm shall pass through each tube after the test.

Off reel testing: Not applicable.

Weathering: Not applicable.

Fluid immersion:

Standard performance product: Exposure to automobile gasoline and tap water are not required and the test temperature for lubricating oil exposure shall be 73 to 77 °C. The tensile strength retention of the cable jacket material after exposure to hydraulic fluid shall be not less than 30 percent.

Enhanced performance product: Exposure to automobile gasoline and tap water are not required and the following test temperatures shall be used for the fluids indicated: fuel oil (98 to 100 °C), turbine fuel (48 to 50 °C), and lubricating oil (98 to 100 °C).

Flame extinguishing and smoke generation: Applicable. Tube ends shall be plugged with a non-flammable sealant to simulate end caps.

Shock: Applicable. A minimum of three fibers located in the center tube shall be monitored during the shock test.

Chemical properties:

Halogen content: <0.2 percent

Cross-link verification: This test is applicable for cables with cross-linked jackets only. The test shall be conducted in accordance with ICEA standard T-28-562 and run at 200 °C. The test shall be sequenced after the fluid immersion test in the qualification test sequence and in the Group C conformance test sequence. The hot creep shall not exceed 100 percent and the hot creep set shall not exceed 10 percent.

Part or identifying number (PIN):

M85045/25-01S (Standard performance)

M85045/25-01E (Enhanced performance, cross-linked outer jacket)

Qualification and conformance inspection: See [table I](#).

TABLE I. Qualification and conformance inspection.

Group	Qualification inspection	Requirement paragraph	Test paragraph	Cable length ^{1/} ^{2/}	Conformance inspection
I	Visual and mechanical inspection	3.4, 3.9, 3.10	4.7.2	2 samples, 0.3 km each ^{3/}	A
	Pressure withstand	^{4/}	^{4/}	2 specimens, 2 m each ^{3/}	--
III	Temperature cycling	3.7.1	^{4/}	2 samples, 0.3 km each ^{5/} (1 on reel, 1 off)	C
	Temperature humidity cycling	3.7.3	4.7.6.3	2 samples, 0.3 km each ^{6/}	C
	Storage temperature	3.7.4	4.7.6.4	2 samples, 0.3 km each ^{6/}	--
	Low temperature flexibility (cold bend)	3.6.3	4.7.5.3	2 specimens, 8 m each ^{7/}	B
	Cyclic flexing	3.6.4	4.7.5.4	6 specimens, 5 m each ^{8/} (2 specimens at each temp)	--
	Crush	3.6.5	4.7.5.5	2 specimens, 5 m each ^{7/}	--
	Impact	3.6.8	4.7.5.8	2 specimens, 5 m each ^{6/}	C
	Temperature life (life aging)	^{4/}	^{4/}	2 specimens, 150 m each ^{7/}	C
	Tensile loading and elongation	3.6.1	4.7.5.1	2 specimens, 150 m each ^{9/}	C
	Operating tensile loading	3.6.1.1	4.7.5.1.1	2 specimens, 150 m each ^{10/}	C
	Fungus resistance	3.8.4	4.8.4	2 specimens, 0.5 m each ^{7/}	--
	Cable element removability	3.6.18	4.7.5.18	2 specimens, 0.5 m each ^{7/}	C
IV	Fluid immersion	3.7.9	4.7.6.9	1 specimen, 2 m ^{11/} and 3 material samples ^{12/} for each specified fluid	C
	Paint susceptibility	3.7.15	4.7.6.15	2 specimens, 2 m ^{13/}	--
	Jacket self-adhesion or blocking	3.7.11	4.7.6.11	1 specimen, 30 m ^{11/}	--
	Shock	3.7.13	4.7.6.13	1 specimen, 30 m ^{11/}	--
	Tube tensile strength and elongation	^{4/}	^{4/}	1 specimen, 1 m	--
	Hosing: low pressure	3.6.12.1	4.7.5.12.1	1 specimen, 1.5 m ^{11/}	C
	Radial compression (for application B only)	3.6.7	4.7.5.7	1 specimen, 10 m ^{11/}	--
	Corner bend	3.6.9	4.7.5.9	2 specimens, 5 m ^{13/}	--
	Cross-link verification	^{4/}	^{4/}	2 specimens, 1 m ^{11/}	C

TABLE I. Qualification and conformance inspection – Continued.

Group	Qualification inspection	Requirement paragraph	Test paragraph	Cable length ^{1/} ^{2/}	Conformance inspection
V	Dripping	3.6.13	4.7.5.13	1 specimen, 30 cm ^{11/}	--
	Cable jacket tear strength	3.6.14	4.7.5.14	5 flat extruded jacket material strips ^{14/}	C
	Cable jacket material tensile strength and elongation	3.6.15	4.7.5.15	5 specimens ^{15/}	--
	Cable abrasion resistance	3.6.16	4.7.5.16	4 specimens, 2 m ^{16/}	C
	Cable shrinkage	3.6.17	4.7.5.17	3 specimens, 0.5 m ^{13/}	C
	Durability of identification	3.6.19	4.7.5.19	3 specimens, 2 m each ^{13/}	--
	Flame extinguishing and smoke generation	3.7.12.2	4.7.6.12.2	1 specimen, 50 m ^{11/}	C
	Water absorption	3.7.14	4.7.6.14	2 specimens, extruded jacket material strips ^{15/}	--
VI	Acid gas generation	3.8.1	4.8.1	1 specimen, 1 m ^{17/}	C
	Halogen content	3.8.2	4.8.2	1 specimen, 1 m ^{17/}	--
	Toxicity index	3.8.3	4.8.3	1 specimen, 1 m ^{17/}	C
	Smoke index	3.8.5	4.8.6	1 specimen, 1 m ^{17/}	C

NOTES:

- ^{1/} Tolerance on 0.3-km length is ± 5 percent.
- ^{2/} Tolerance on shorter lengths is ± 5 percent.
- ^{3/} The inspection shall only be conducted on a 2-m section of each sample.
- ^{4/} As stated under the applicable tests in this specification sheet.
- ^{5/} The same samples as used in the visual and mechanical inspection shall be used.
- ^{6/} The same samples as used in the temperature cycling test shall be used.
- ^{7/} A specimen cut from each sample used in the temperature cycling test shall be used.
- ^{8/} Three specimens cut from each sample used in the temperature cycling test shall be used.
- ^{9/} A specimen cut from each specimen used in the temperature life test shall be used.
- ^{10/} The same specimen as used in the tensile loading and elongation test shall be used.
- ^{11/} A specimen cut from the specimen used in the temperature cycling test shall be used.
- ^{12/} Three flat extruded jacket material strips as specified in 4.7.5.15 shall be used in this test.
- ^{13/} Specimens cut from the specimen used in the temperature cycling test shall be used.
- ^{14/} Flat extruded jacket material strips (i.e., strips of flat extruded material with the same composition of the cable jacket and of sufficient dimensions in which dumbbells can be cut) prepared as specified in 4.7.5.14 cited method and obtained from flat extruded material that underwent the temperature cycling test shall be used.
- ^{15/} Flat extruded jacket material as specified in 4.7.5.15 shall be used in this test.
- ^{16/} Specimens cut from the sample used in the temperature cycling test shall be used. Two specimens shall be used for scraping abrasion, and two specimens shall be used in the cable-to-cable abrasion testing.
- ^{17/} A specimen cut from one of the samples used in the temperature cycling test shall be used.

Manufacturers who produce products for MIL-PRF-85045/17-01 or MIL-PRF-85045/22E enhanced performance and this specification sheet, and are qualified under M85045/17 or M85045/22E enhanced performance, and whose enhanced performance product passes all tests identified in [table II](#), are qualified under this specification sheet for enhanced performance product (M85045/25E). This qualification by similarity is applicable if the same cable jacket materials are used in the previously qualified MIL-PRF-85045/17 cable and the enhanced performance cable under test.

Manufacturers who produce products for both MIL-PRF-85045/22 and this specification sheet, and are qualified under M85045/22, and whose standard performance product passes all tests identified in [table II](#), are qualified under this specification sheet for standard performance product (M85045/25-01S). This qualification by similarity is applicable if the same cable jacket materials are used in the previously qualified MIL-PRF-85045/22 cable and the standard performance cable under test.

TABLE II. Qualification and conformance by similarity for M85045/25-01E to M85045/22E or M85045/17 and M85045/25-01S to M85045/22.

Group	Qualification inspection	M85045/25-01S Qualification inspection ^{1/}	M85045/25-01S Conformance inspection ^{2/}	M85045/25-01E Qualification inspection ^{3/}	M85045/25-01E Conformance inspection ^{4/}
I	Visual and mechanical inspection	X	A	X	A
	Pressure withstand	X	--	X	--
III	Temperature cycling	X	C	X	C
	Temperature humidity cycling	X	C	X	C
	Storage temperature	X	--	X	--
	Low temperature flexibility (cold bend)	X	B	X	B
	Cyclic flexing	X	--	X	--
	Crush	X	--	X	--
	Impact	X	C	X	C
	Temperature life (life aging)	X	C	X	C
	Tensile loading and elongation	X	C	X	C
	Operating tensile loading	X	C	X	C
	Fungus resistance	X	--	X	--
	Cable element removability	X	C	X	C
IV	Shock	X	--	X	--
	Tube tensile strength and elongation	X	--	X	--
	Hosing: low pressure	X	C	X	C
	Radial compression (for application B only)	X	--	X	--

TABLE II. Qualification and conformance by similarity for M85045/25-01E to M85045/22E or M85045/17 and M85045/25-01S to M85045/22 – Continued.

Group	Qualification inspection	M85045/25-01S Qualification inspection ^{1/}	M85045/25-01S Conformance inspection ^{2/}	M85045/25-01E Qualification inspection ^{3/}	M85045/25-01E Conformance inspection ^{4/}
	Corner bend	X	--	X	--
	Cross-link verification	X	--	X	--
V	Dripping	X	--	X	--
	Cable abrasion resistance	X	C	X	C
	Cable shrinkage	X	C	X	C
	Flame extinguishing and smoke generation	X	C	X	C
	Water absorption	X	--	X	--
VI	Acid gas generation	X	C	X	C
	Halogen content	X	--	X	--
	Toxicity index	X	C	X	C
	Smoke index	X	C	X	C

NOTES:

^{1/} Where manufacturers are qualified for MIL-PRF-85045/22 and are pursuing qualification for MIL-PRF-85045/25-01S.

^{2/} Where manufacturers are qualified for MIL-PRF-85045/22 and MIL-PRF-85045/25-01S and are performing conformance testing for M85045/25-01S.

^{3/} Where manufacturers are qualified for MIL-PRF-85045/17 and are pursuing qualification for MIL-PRF-85045/25-01E.

^{4/} Where manufacturers are qualified for MIL-PRF-85045/17 and MIL-PRF-85045/25-01E and are performing conformance testing for M85045/25-01E.

Qualification by similarity for change to outer cable jacket:

Manufacturers who produce products for MIL-PRF-85045/25 using one particular overall cable jacket compound and are qualified under MIL-PRF-85045/25 for that compound and pass all tests identified in [table III](#) for cables with a modified overall cable jacket compound or modified cable jacket color are also qualified under MIL-PRF-85045/25 for cables with the modified overall cable jacket.

TABLE III. Qualification by similarity for change in cable jacket compound or color.

Group	Qualification inspection	Modified overall cable jacket compound	Modified cable jacket color ^{1/}
I	Visual and mechanical inspection	X	X
III	Low temperature flexibility (cold bend)	X	X
	Cyclic flexing	^{3/}	--
	Temperature life (life aging)	^{3/}	--
	Fungus resistance	^{4/}	^{4/}
IV	Fluid immersion	X	--
	Paint susceptibility	X	--

TABLE III. Qualification by similarity for change in cable jacket compound or color – Continued.

Group	Qualification inspection	Modified overall cable jacket compound	Modified cable jacket color ^{1/}
	Jacket self-adhesion or blocking	X	--
	Hosing: low pressure	^{2/}	^{2/}
	Cross-link verification	X	X
V	Dripping	X	--
	Cable jacket tear strength	^{3/}	--
	Cable jacket material tensile strength and elongation	X	X
	Cable abrasion resistance	X	--
	Cable shrinkage	^{2/}	^{2/}
	Durability of identification	X	X
	Flame extinguishing and smoke generation	X	X
	Water absorption	X	X
VI	Acid gas generation	X	X
	Halogen content	X ^{5/}	X ^{5/}
	Toxicity index	X	X
	Smoke index	X	X

NOTES:

^{1/} Perform if only colorants have changed.

^{2/} Perform if process conditions change.

^{3/} Perform if results of cable jacket material tensile strength and elongation for the modified cable jacket are not the same as the qualified cable jacket.

^{4/} Perform unless fungus inert in accordance with MIL-HDBK-454.

^{5/} If information on formulation of colorants provided, test may be waived.

Qualification by similarity for change to tube:

Manufacturers who produce products for MIL-PRF-85045/25 using one particular tube and are qualified under MIL-PRF-85045/25 for that tube and pass all tests identified in [table IV](#) for cables with a modified tube are also qualified under MIL-PRF-85045/25 for cables with the modified tube.

TABLE IV. Qualification by similarity for change in tube.

Group	Qualification inspection	Change to tube
I	Visual and mechanical inspection	X
III	Temperature cycling	X
	Temperature humidity cycling	X
	Storage temperature	X
	Low temperature flexibility (cold bend)	X
	Cyclic flexing	X
	Impact	X
	Temperature life (life aging)	X
	Fungus resistance	X ^{1/}

TABLE IV. Qualification by similarity for change in tube – Continued.

Group	Qualification inspection	Change to tube
IV	Radial compression (for application B only)	X
V	Dripping	X
	Cable shrinkage	X
	Flame extinguishing and smoke generation	X
VI	Acid gas generation	X
	Halogen content	X
	Toxicity index	X
	Smoke index	X
NOTE: ^{1/} Perform unless fungus inert in accordance with MIL-HDBK-454.		

CHANGES FROM PREVIOUS ISSUE: Marginal notations are not used in this revision to identify changes with respect to the previous issue due to the extent of the changes.

Custodians:

Army – CR
Navy – SH
Air Force – 85
NASA – NA

Preparing activity:

Navy – SH
(Project 6015-2012-020)

Review activities:

Army – AR, AV, MI
Navy – EC, YD
Air Force – 02, 19, 99
DLA – CC

NOTE: The activities listed above were interested in this document as of the date of this document. Since organizations and responsibilities can change, you should verify the currency of the information above using the ASSIST Online database at <https://assist.dla.mil>.