

METRIC

MIL-PRF-85045/24A

17 June 2014

SUPERSEDING

MIL-PRF-85045/24

26 July 1999

PERFORMANCE SPECIFICATION SHEET

CABLE, FIBER OPTIC, NINETY FIBERS, ENHANCED PERFORMANCE, CABLE CONFIGURATION TYPE 2 (OFCC), APPLICATION B (SHIPBOARD), CABLE CLASS SM AND MM

This specification is approved for use by all Departments and Agencies of the Department of Defense.

The requirements for acquiring the product described herein shall consist of this specification sheet and MIL-PRF-85045.

CLASSIFICATION:

Fiber optic cable configuration type: 2 (OFCC)

Fiber optic cable class: MM (graded-index, glass core and glass cladding, multimode)

SM (dispersion-unshifted, glass core and glass cladding, single-mode)

DESIGN AND CONSTRUCTION:

Fiber: Class MM fibers shall be in accordance with MIL-PRF-49291/6.

Class SM fibers shall be in accordance with MIL-PRF-49291/7.

Buffer diameter: $900 \pm 50 \mu\text{m}$

OFCC:

Dimensions and configuration: See [figure 1](#).

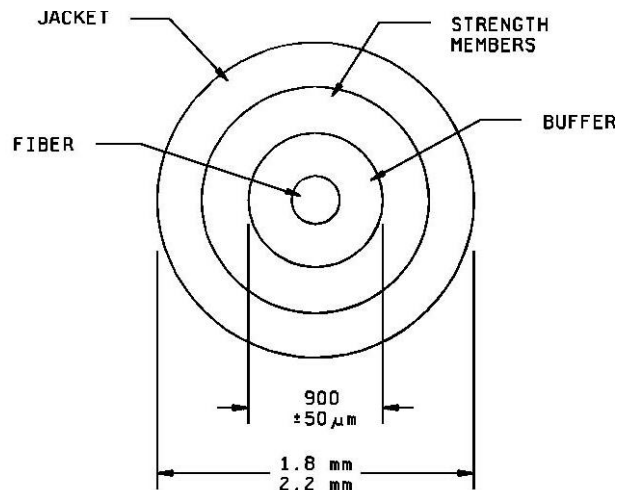

FIGURE 1. Optical fiber cable component.

Mass per unit length: <15 kg/km

Tensile loading: >270 N

Dynamic bend tensile load: 90 N minimum

Jacket material: The OFCC jacket shall be composed of a low halogen, low smoke, low toxicity polymer material.

Cable jacket color: Shall be black or blue.

OFCC color:

Slate (MIL-PRF-49291/6 fiber)

Yellow (MIL-PRF-49291/7 fiber)

OFCC marking: Each OFCC shall be uniquely marked with a number between 1 and 18. The form of the marking shall be the printed spelling of the number, followed by a dash, followed by the printed Arabic numeral. The marking shall be applied and repeated every 0.10 m along the OFCC jacket.

Short-term minimum bend diameter: Eight times the OFCC outer diameter.

Long-term minimum bend diameter: Sixteen times the OFCC outer diameter.

Eighteen fiber sub-cables:

Eighteen fiber sub-cables shall be in accordance with MIL-PRF-85045/22-01 or MIL-PRF-85045/22-02 standard performance, except that the minimum outer jacket thickness shall be not less than 0.9 mm.

OFCC number one shall be located in the innermost ring of OFCCs. OFCCs shall be consecutively numbered starting with those in the innermost ring (1 through 6) and then those in the outer ring (7 through 18). OFCCs 1 and 7 shall be located along approximately the same radial line within the cable.

Sub-cable marking: Each sub-cable shall be uniquely marked with a sub-cable number between 1 and 5. The marking shall be applied and repeated every 0.5+0.1 m along the sub-cable jacket. The form of the marking shall be the printed spelling of the sub-cable number, followed by a dash, followed by the printed Arabic sub-cable numeral.

Finished cable:

Dimensions and configuration: See [figure 2](#). Five sub-cables shall be helically laid over the central member. The minimum outer jacket thickness shall be not less than 1.9 mm.

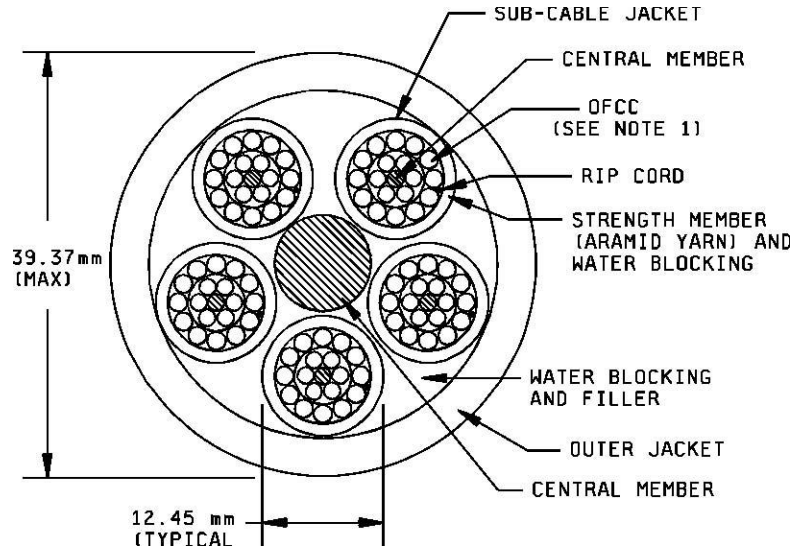

NOTE:

1. OFCC - Optical fiber cable component.

FIGURE 2. Ninety-OFCC fiber optic cable.

Number of fibers: 90 (one per OFCC)

Concentricity: >0.65

Mass per unit length: <1350 kg/km

Jacket material: The overall jacket shall be composed of a low halogen, low smoke, low toxicity polymer material.

Short-term minimum bend diameter: Eight times the cable outer diameter. (The short-term minimum bend diameter is to be used in all environmental and mechanical tests which specify a cable minimum bend diameter.)

Long-term minimum bend diameter: Sixteen times the cable outer diameter.

Minimum continuous length: The minimum continuous length of all cables shall be not less than 0.5 km. If lengths less than 0.5 km are specified in the purchase order, a conformance inspection shall be performed on test specimens not less than 0.5 km in length from which the purchase order lengths are cut.

PERFORMANCE REQUIREMENTS:

Optical properties:

Maximum attenuation rate: 4.5 dB/km at 850 ± 20 nm, 2.0 dB/km at 1300 ± 20 nm for Class MM fiber.

2.0 dB/km at 1310 ± 20 nm and 1550 ± 20 nm for Class SM fiber.

For cables with radiation cross-linked jackets, the change in attenuation rate measurement may be made up to 30 days after cross-linking of the cable jacket.

Bandwidth: Fiber with a minimum bandwidth of 500 MHz-km at 1300 nm and 160 MHz-km at 850 nm shall be used (multimode cables only).

Change in optical transmittance: Measurements shall be made at 1300 ± 20 nm. A minimum of fifteen fibers shall be monitored for change in optical transmittance. A minimum of one fiber shall be monitored in the inner ring of OFCCs of each sub-cable. A minimum of two fibers shall be monitored in the outer ring of OFCCs of each sub-cable. The fibers monitored in each ring shall be randomly selected, but different fibers shall be monitored in each test sample. For shock testing, only four fibers are required to be monitored (one each in four of the five eighteen fiber sub-cables).

Mechanical properties:

Tensile loading and elongation: Not applicable.

Operating tensile loading: Not applicable.

Dynamic bend: Not applicable.

Low temperature flexibility: The exposure temperature shall be -40 °C.

Cyclic flexing: 500 cycles at 25 ± 2 °C and 100 cycles at -28 ± 2 °C. Change in optical transmittance measurements are to be made every 100 cycles for the 500-cycle exposure and every 25 cycles for the 100-cycle exposure. Each change in optical transmittance measurement shall be performed with the test specimen in the same test position in the test cycle. The cycling may be halted to perform the change in optical transmittance measurement.

Crush: Not applicable.

Cable twist-bending: 500 cycles at 25 ± 2 °C and 100 cycles at -28 ± 2 °C. Change in optical transmittance measurements are to be made every 100 cycles for the 500-cycle exposure and every 25 cycles for the 100-cycle exposure. Each change in optical transmittance measurement shall be performed with the test specimen in the same test position in the test cycle. The cycling may be halted to perform the change in optical transmittance measurement.

Impact: 50 cycles at 25 ± 2 °C and 20 cycles at -40 ± 2 °C. Upon final visual examination at all tested temperatures, there shall be no jacket damage such as splitting or cracking.

Corner bend: Not applicable.

Hosing: Both low pressure and hydrostatic pressure are applicable.

Low pressure: Leakage shall be not greater than 450 ml.

Hydrostatic: 2.1 MPa

Cable scraping resistance: 750 cycles

Cable-to-cable abrasion: 500 cycles

Stuffing tube compression: A fully assembled cable specimen shall be tested as follows. One end of the specimen shall be fitted into the appropriate size of bulkhead stuffing tube (refer to MIL-STD-2042 for guidance in choosing the appropriate size bulkhead stuffing tube). The stuffing tube shall be torqued to 115 N m (the maximum distance between the gland nut and the stuffing tube body shall be 3.2 mm) and conditioned at ambient temperature for 24 hours. The stuffing tube shall be torqued a second time to 115 N m, conditioned for a second 24 hours, torqued a third time, and conditioned for a final 24 hours. Change in optical transmittance measurements shall be made approximately 5 minutes before and after the stuffing tube is torqued and once every 3 hours during the conditioning periods. The change in optical transmittance shall be not greater than 0.5 dB during and after the test.

Environmental properties:

Temperature range:

Operating: -28 to 65 °C

Nonoperating: -40 to 70 °C

Storage: -40 to 70 °C

Temperature cycling: Change in optical transmittance measurements may be made periodically. At a minimum, one optical transmittance measurement shall be made over a period of 1 hour at the end of each temperature plateau.

Temperature/humidity cycling: Change in optical transmittance measurements may be made periodically. At a minimum, one optical transmittance measurement shall be made at the end of each temperature plateau.

Temperature life (life aging): The jacket material shall be tested at 175 °C for 4 hours.

Fluid immersion: Exposure to automobile gasoline and tap water are not required and the following test temperatures shall be used for the fluids indicated: fuel oil (98 to 100 °C), turbine fuel (48 to 50 °C), and lubricating oil (98 to 100 °C).

Flame extinguishing and smoke generation: Applicable.

Chemical properties:

Halogen content: <0.2 percent

Shock: Applicable.

Cross-link verification: This test is applicable for cables with cross-linked jackets only. The test shall be conducted in accordance with ICEA standard T-28-562 and run at 200 °C. The test shall be sequenced after the weathering test in the qualification test sequence and after the fluid immersion test in the Group C conformance test sequences. The hot creep shall not exceed 100 percent and the hot creep set shall not exceed 10 percent.

Part or identifying number (PIN):

M85045/24-01 (Multimode)

M85045/24-02 (Single-mode)

Qualification and conformance inspection: See [table I](#).

TABLE I. Qualification and conformance inspection.

Group	Qualification inspection	Requirement paragraph	Test paragraph	Cable length ^{1/ 2/}	Conformance inspection
I	Visual and mechanical inspection	3.4, 3.9, 3.10	4.7.2	3 samples, 0.5 km each ^{3/}	A
	Attenuation rate	3.5.1	4.7.4.1	3 samples, 0.5 km each ^{4/}	A
III	Temperature cycling	3.7.1	^{5/}	2 samples, 0.5 km each ^{4/} (1 on reel, 1 off)	C
	Temperature humidity cycling	3.7.3	4.7.6.3	2 samples, 0.5 km each ^{6/}	C
	Storage temperature	3.7.4	4.7.6.4	2 samples, 0.5 km each ^{6/}	--

TABLE I. Qualification and conformance inspection – Continued.

Group	Qualification inspection	Requirement paragraph	Test paragraph	Cable length ^{1/ 2/}	Conformance inspection
	Low temperature flexibility (cold bend)	3.6.3	4.7.5.3	2 specimens, 8 m each ^{7/}	B
	Cyclic flexing	3.6.4	4.7.5.4	6 specimens, 5 m each ^{8/} (2 specimens at each temp)	--
	Cable twist-bend	3.6.6	4.7.5.6	6 specimens, 5 m each ^{8/} (3 specimens at each temp)	--
	Impact	3.6.8	4.7.5.8	2 units, 5 m each ^{7/}	--
	Temperature life (life aging)	^{5/}	^{5/}	2 specimens, 300 m each ^{7/}	C
	Fungus resistance	3.8.4	4.8.4	2 specimens, 0.5 m each ^{7/}	--
	Cable element removability	3.6.18	4.7.5.18	2 specimens, 0.5 m each ^{7/}	C
IV	Thermal shock	3.7.2	4.7.6.2	1 specimen, 0.49 km each ^{4/} (on reel)	--
	Weathering	3.7.8	4.7.6.8	1 specimen, 2 m ^{9/} and 3 material samples ^{10/}	--
	Fluid immersion	3.7.9	4.7.6.9	1 specimen, 2 m ^{9/} and 3 material samples ^{10/} for each specified fluid	C
	Paint susceptibility	3.7.15	4.7.6.15	2 specimens, 2 m ^{9/}	--
	Jacket self-adhesion or blocking	3.7.11	4.7.6.11	1 specimen, 30 m ^{9/}	--
	Shock	3.7.13	4.7.6.13	1 specimen, 30 m ^{9/}	--
	Hosing: low pressure	3.6.12.1	4.7.5.12.1	1 specimen, 1.5 m ^{9/}	C
	Hosing: hydrostatic	3.6.12.2	4.7.5.12.2	1 specimen, 2 m ^{9/}	C
	Radial compression (for application B only)	3.6.7	4.7.5.7	1 specimen, 10 m ^{9/}	--
	OFCC kink	^{5/}	^{5/}	2 specimens, 1 m ^{9/}	--
	Cross-link verification	^{5/}	^{5/}	2 specimens, 1 m ^{9/}	C
V	Dripping	3.6.13	4.7.5.13	1 specimen, 30 cm ^{9/}	--
	Cable jacket tear strength	3.6.14	4.7.5.14	5 flat extruded jacket material strips ^{11/}	C
	Cable jacket material tensile strength and elongation	3.6.15	4.7.5.15	5 specimens ^{12/}	--
	Cable abrasion resistance	3.6.16	4.7.5.16	4 specimens, 2 m ^{13/}	C
	Cable shrinkage	3.6.17	4.7.5.17	3 specimens, 0.5 m ^{14/}	C
	Durability of identification	3.6.19	4.7.5.19	3 specimens, 2 m each ^{14/}	--

TABLE I. Qualification and conformance inspection – Continued.

Group	Qualification inspection	Requirement paragraph	Test paragraph	Cable length ^{1/ 2/}	Conformance inspection
	Stuffing tube compression	3.6.21	4.7.5.21	1 specimen, 3m ^{9/}	--
	Flame extinguishing and smoke generation	3.7.12.2	4.7.6.12.2	1 specimen, 50 m ^{9/}	C
	Water absorption	3.7.14	4.7.6.14	2 specimens, extruded jacket material strips ^{12/}	--
VI	Acid gas generation	3.8.1	4.8.1	1 specimen, 1 m ^{15/}	C
	Halogen content	3.8.2	4.8.2	1 specimen, 1 m ^{15/}	--
	Toxicity index	3.8.3	4.8.3	1 specimen, 1 m ^{15/}	C
	Smoke index	3.8.5	4.8.6	1 specimen, 1 m ^{15/}	C

NOTES:

- ^{1/} Tolerance on 0.5 km length is ± 5 percent, provided that results are normalized to 1 km.
- ^{2/} Tolerance on shorter lengths is ± 5 percent.
- ^{3/} The visual and mechanical inspection shall only be conducted on a 2-m section of each sample.
- ^{4/} The same samples as used in the visual and mechanical inspection shall be used.
- ^{5/} As stated under the applicable tests in this specification sheet.
- ^{6/} The same samples as used in the temperature cycling test shall be used.
- ^{7/} A specimen cut from each sample used in the temperature cycling test shall be used.
- ^{8/} Three specimens cut from each sample used in the temperature cycling test shall be used.
- ^{9/} Specimen cut from the specimen used in the thermal shock test shall be used.
- ^{10/} Three flat extruded jacket material strips as specified in 4.7.5.15 shall be used in this test.
- ^{11/} Flat extruded jacket material strips (i.e., strips of flat extruded material with the same composition of the cable jacket and of sufficient dimensions in which dumbbells can be cut) prepared as specified in 4.7.5.14 cited method and obtained from flat extruded material that underwent the thermal shock test shall be used.
- ^{12/} Flat extruded jacket material as specified in 4.7.5.15 shall be used in this test.
- ^{13/} Specimen cut from the specimen used in the thermal shock test shall be used. Two specimens shall be used for scraping abrasion and two specimens shall be used in the cable-to-cable abrasion testing.
- ^{14/} Specimens cut from the specimen used in the thermal shock test shall be used.
- ^{15/} A specimen cut from one of the samples used in the temperature cycling test or specimen used in the thermal shock test shall be used.

Manufacturers who are qualified under MIL-PRF-85045/17-01, MIL-PRF-85045/18-01 or MIL-PRF-85045/20-01, and MIL-PRF-85045/22E-01, and whose cable passes all tests and inspections specified in [table II](#), are qualified under this specification sheet. This qualification by similarity is applicable only if the same eighteen fiber cables (with the exception of cable jacket thickness) and same cable materials used in the previously qualified cables are used in the cable under test. Testing may be performed on a single length of cable, with a minimum length of 0.5 km.

TABLE II. Qualification and conformance by similarity (cable).

Group	Qualification inspection	Qualification inspection ^{1/}	Conformance inspection ^{2/}
I	Visual and mechanical	X	A
	Attenuation rate	X	A
III	Temperature cycling	X	C
	Temperature humidity cycling	X	C
IV	Hosing: low pressure and hydrostatic	X	C
	Radial compression	X	--
V	Cable jacket tear strength	X	C
	Cable jacket material tensile strength and elongation	X	C
	Cross-link verification	X	C
VI	Flame extinguishing and smoke generation	X	C
	Acid gas generation	X	C

NOTES:

^{1/} Where manufacturers are qualified for MIL-PRF-85045/17-01, MIL-PRF-85045/18-01, or MIL-PRF-85045/20-01, and MIL-PRF-85045/22E-01 and are pursuing qualification for M85045/24-01E.

^{2/} Where manufacturers are qualified for M85045/17-01 and M85045/22-01 and are performing conformance testing for M85045/24-01E.

Manufacturers who are qualified under this specification sheet for multimode (M85045/24-01) fiber cable and whose single-mode fiber cable passes all tests and inspections specified in [table III](#) are qualified under this specification sheet for single-mode (M85045/24-02) fiber cable. This qualification by similarity is applicable if the only difference between the previously qualified cable and the cable under test is that the optical fiber has been changed from a multimode fiber to a single-mode fiber. Testing may be performed on either one or two lengths of cable, each with a minimum length of 0.5 km. Test order must be observed up to and including the storage temperature test. If only one cable length is used, the thermal shock test shall be performed after the storage temperature test.

TABLE III. Qualification and conformance by similarity (fiber).

Group	Inspection	Qualification inspection M85045/24-02 ^{1/}	Conformance inspection M85045/24-02 ^{2/}
I	Visual and mechanical	X	A
	Attenuation rate	X	A
III	Temperature cycling	X	C
	Temperature humidity cycling	X	--
	Storage temperature	X	--
	Cyclic flexing	X	--
	Crush	X	--
	Cable twist-bending	X	C
	Impact (low temperature only)	X	C
IV	Thermal shock	X	--

TABLE III. Qualification and conformance by similarity (fiber) – Continued.

NOTES:

- ^{1/} Where manufacturers are qualified for MIL-PRF-85045/24-01 and are pursuing qualification for MIL-PRF-85045/24-02.
- ^{2/} Where manufacturers are qualified for MIL-PRF-85045/24-01 and MIL-PRF-85045/24-02 and are performing conformance testing for M85045/24-02.

CHANGES FROM PREVIOUS ISSUE: Marginal notations are not used in this revision to identify changes with respect to the previous issue due to the extent of the changes.

Custodians:

Army – CR
Navy – SH
Air Force – 85
NASA – NA

Preparing activity:

Navy – SH
(Project 6015-2012-019)

Review activities:

Army – AR, AV, MI
Navy – EC, YD
Air Force – 02, 19, 99
DLA – CC

NOTE: The activities listed above were interested in this document as of the date of this document. Since organizations and responsibilities can change, you should verify the currency of the information above using the ASSIST Online database at <https://assist.dla.mil>.