

METRIC

MIL-PRF-85045/23
26 July 1999

PERFORMANCE SPECIFICATION SHEET

CABLE, FIBER OPTIC, EIGHTEEN FIBERS, ENHANCED PERFORMANCE, CABLE CONFIGURATION
TYPE 2 (OFCC), FOR SUBMARINE OUTBOARD USE ONLY (NOT FOR INBOARD USE),
CABLE CLASS SM AND MM, (METRIC)

This specification is approved for use by all Departments and Agencies of the Department of Defense.

The requirements for acquiring the product described herein shall consist of this specification and MIL-PRF-85045.

CLASSIFICATION:

Fiber optic cable configuration type: 2 (OFCC).

Fiber Cable Class: MM (Graded-index, glass core and glass cladding, multimode).
SM (Dispersion-unshifted, glass core and glass cladding, single-mode).

DESIGN AND CONSTRUCTION:

Fiber:

Class MM fibers shall be in accordance with MIL-PRF-49291/6.
Class SM fibers shall be in accordance with MIL-PRF-49291/7.

Buffer diameter: $900 \pm 50 \mu\text{m}$.

OFCC:

Dimensions and configuration: See figure 1.

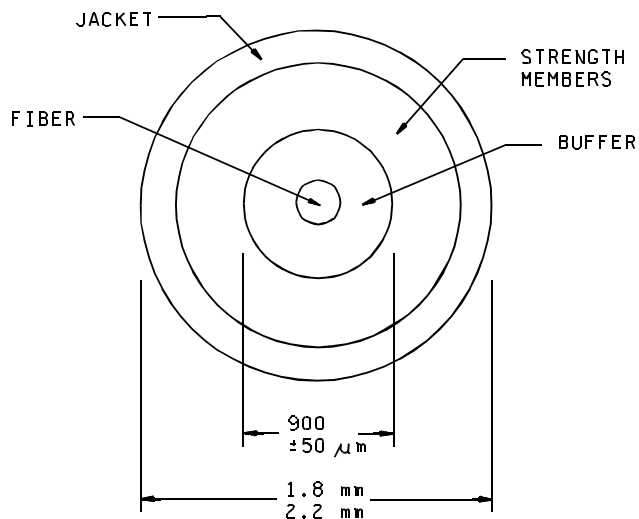

NOTE:

1. Dimensions are in millimeters.

FIGURE 1. Optical fiber cable component.

Mass per unit length: ≤ 15 kg/km.

Tensile loading: ≥ 270 N.

Dynamic bend tensile load: 90 N minimum.

Jacket material: The OFCC jacket shall be composed of a low halogen, low smoke, low toxicity polymer material.

OFCC Color:

- Slate (MIL-PRF-49291/6 fiber).
- Yellow (MIL-PRF-49291/7 fiber).

OFCC marking: Each OFCC shall be uniquely marked with a number between 1 and 18. The form of the marking shall be the printed spelling of the number, followed by a dash, followed by the printed arabic numeral. The marking shall be applied and repeated every 0.10 m along the OFCC jacket.

Short term minimum bend diameter: Eight times the OFCC outer diameter.

Long term minimum bend diameter: Sixteen times the OFCC outer diameter.

Finished cable:

Dimensions and configuration: See figure 2. Eighteen OFCC units shall be helically laid over the central member. OFCC number one shall be located in the innermost ring of OFCC's. OFCC's shall be consecutively numbered starting with those in the innermost ring (one through six) and then those in the outer ring (seven through eighteen). OFCC's one and seven shall be located along approximately the same radial line within the cable. Materials with acoustic performance properties similar to those of Mylar shall not be used. The outer jacket may be composed of multiple layers. The total jacket wall thickness shall be a minimum of 2.8 mm.

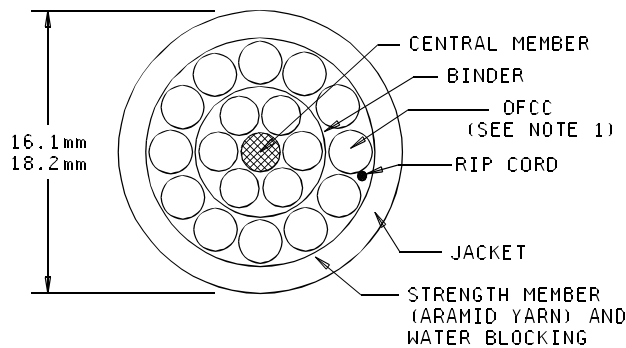

NOTE:

1. OFCC - Optical fiber cable component.

FIGURE 2. Eighteen OFCC fiber optic cable.

Number of fibers: 18 (one per OFCC).

Concentricity: ≥ 0.65 .

Mass per unit length: ≤ 250.0 kg/km.

Jacket material: The outer jacket shall be arctic type polychloroprene (black).

Short term minimum bend diameter: Eight times the cable outer diameter. (The short term minimum bend diameter is to be used in all environmental and mechanical tests which specify a cable minimum bend diameter.)

Long term minimum bend diameter: Sixteen times the cable outer diameter.

Minimum continuous length: The minimum continuous length of all cables shall be not less than 0.5 km. If lengths less than 0.5 km are specified in the purchase order, Quality Conformance Inspection shall be performed on test specimens not less than 0.5 km in length from which the purchase order lengths are cut.

PERFORMANCE REQUIREMENTS:

Optical properties:

Maximum attenuation rate: 4.5 dB/km at 850 ± 20 nm, 2.0 dB/km at 1300 ± 20 nm for class MM fiber.
2.0 dB/km at 1310 ± 20 nm and 1550 ± 20 nm for class SM fiber.

Bandwidth: Fiber with a minimum bandwidth of 500 MHz-km at 1300 nm and 160 MHz-km at 850 nm shall be used (multimode cables only).

Change in optical transmittance: Measurements to be made at 1300 ± 20 nm. A minimum of eight fibers shall be monitored for change in optical transmittance. A minimum of two fibers shall be monitored in the inner ring of OFCC's. A minimum of 6 fibers shall be monitored in the outer ring of OFCC's. The fibers monitored in each ring shall be randomly selected, but different fibers shall be monitored in each test sample. For shock testing only four fibers are required to be monitored (two in the inner ring and two in the outer ring of OFCC's).

Crosstalk: Applicable.

Mechanical properties:

Tensile loading and elongation: Applicable, tensile loading $\geq 3,300$ N.

Operating tensile loading: Applicable.

Low temperature flexibility: The exposure temperature shall be -40°C .

Cyclic flexing: 500 cycles at $25^{\circ}\text{C} \pm 2^{\circ}\text{C}$ and 100 cycles at $-28^{\circ}\text{C} \pm 2^{\circ}\text{C}$. Change in optical transmittance measurements are to be made every 100 cycles for the 500 cycle exposure and every 25 cycles for the 100 cycle exposure. Each change in optical transmittance measurement shall be performed with the test specimen in the same test position in the test cycle. The cycling may be halted to perform the change in optical transmittance measurement.

Crush: Applicable.

Cable twist bending: 500 cycles at $25^{\circ}\text{C} \pm 2^{\circ}\text{C}$ and 100 cycles at $-28^{\circ}\text{C} \pm 2^{\circ}\text{C}$. Change in optical transmittance measurements are to be made every 100 cycles for the 500 cycle exposure and every 25 cycles for the 100 cycle exposure. Each change in optical transmittance measurement shall be performed with the test specimen in the same test position in the test cycle. The cycling may be halted to perform the change in optical transmittance measurement.

Radial compression: Applicable.

Impact: 50 cycles at $25^{\circ}\text{C} \pm 2^{\circ}\text{C}$ and 20 cycles at $-40^{\circ}\text{C} \pm 2^{\circ}\text{C}$. Upon final visual examination at all tested temperatures, there shall be no jacket damage such as splitting or cracking.

Pressure cycling: Applicable, the change in optical transmittance shall be less than 1.0 dB during the test and 0.5 dB after the test.

Hosing: Both low pressure and hydrostatic pressure are applicable.

Low pressure test pressure shall be 379 kPa. Leakage shall be not greater than 600 ml after 2 hours and not greater than 2000 ml after 6 hours.

Hydrostatic: 7.7 MPa. There shall be no leakage through the cable core during the first two hours. The total leakage (cable core and OFCC) shall be not greater than 6000 ml after 6 hours.

Dripping: Applicable.

Cable scraping resistance: 750 cycles.

Cable to cable abrasion: 500 cycles.

Environmental properties:

Temperature range:

Operating: -28°C to 65°C.
Nonoperating: -40°C to 70°C.
Storage: -40°C to 70°C.

Temperature cycling: Change in optical transmittance measurements may be made periodically. At a minimum, one optical transmittance measurement shall be made over a period of 1 hour at the end of each temperature plateau.

Temperature/humidity cycling: Change in optical transmittance measurements may be made periodically. At a minimum, one optical transmittance measurement shall be made at the end of each temperature plateau.

Storage temperature: Applicable.

Life aging: The jacket material shall be tested at 100°C for 168 hours. Tensile strength and elongation retention shall be not less than 50%.

Freezing water immersion (ice crush): Applicable.

Weathering: Applicable.

Fluid immersion: Exposure to automobile gasoline and tap water are not required and the following test temperatures shall be used for the fluids indicated: fuel oil (98°C to 100°C), turbine fuel (48°C to 50°C) and lubricating oil (98°C to 100°C).

Shock: Applicable, external wireway mounting shall be used.

Water absorption: 10 mg per square centimeter maximum.

Paint susceptibility: Applicable.

Cross-link verification: This test is applicable for the cable jacket only. The test shall be conducted in accordance with ICEA standard T-28-562 and run at 200°C. The test shall be sequenced after the weathering test in the qualification test sequence and after the fluid immersion test in the group C quality conformance test sequences. The hot creep shall not exceed 100 percent and the hot creep set shall not exceed 10 percent.

Part or Identifying Number (PIN):

M85045/23-01 (Multimode).
M85045/23-02 (Single-mode).

Qualification by similarity. Manufacturers who are qualified under MIL-PRF-85045/22 and MIL-PRF-85045/21 and whose cable passes the visual and mechanical, attenuation rate, cold bend, cyclic flexing, impact, life aging, freezing water, low pressure, hydrostatic, abrasion, and flame extinguishing inspections specified herein, are qualified under this specification sheet. This qualification by similarity is applicable if the only difference between the previously qualified MIL-PRF-85045/22 cable and the cable under test is the outer cable jacket material. Testing may be performed on either one or two lengths of cable, each with a minimum length of 0.5 km.

Manufacturers who are qualified under this specification sheet for multimode (single-mode) fiber cable and whose single-mode (multimode) fiber cable passes the visual and mechanical, attenuation rate, temperature cycling, temperature/humidity cycling, storage temperature, cyclic flexing, crush, cable twist-bending, impact (low temperature only), tensile loading and elongation, operating tensile loading, thermal shock and dynamic bend inspections specified herein, are qualified under this specification sheet for single-mode (multimode) fiber cable. This qualification by similarity is applicable if the only difference between the previously qualified cable and the cable under test is that the optical fiber has been changed from a multimode (single-mode) fiber to a single-mode (multimode) fiber. Testing may be performed on either one or two lengths of cable, each with a minimum length of 0.5 km. Test order must be observed up to and including the storage temperature test. If only one cable length is used, the thermal shock test shall be performed after the storage temperature test.

Review activities:
DLA - CC

Preparing activity:
Navy - SH

Agent:
DLA - CC

(Project 6015-0036-03)